

GRANITE DIAL INDICATOR STANDS

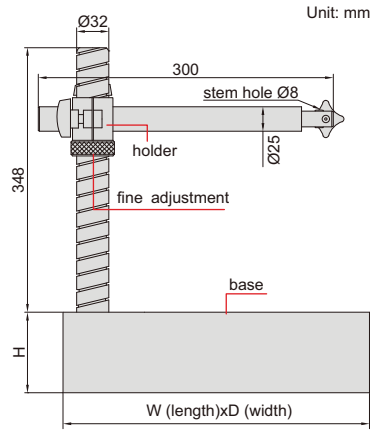

- Vertical travel of holder: 250mm
- Fine adjustment range: entire stroke
- Supplied with dust cover



6867-250



6867-400

Code	Applicable holding stem	W	D	H	Base
6867-250	$\text{Ø}8\text{mm}$	300mm	300mm	75mm	flatness $2.8\mu\text{m}$
6867-400	$\text{Ø}8\text{mm}$	400mm	300mm	100mm	flatness $3\mu\text{m}$